

# ML6425, ML7425 Spring Return Electric Linear Valve Actuators

PRODUCT DATA



## FEATURES

### ML6425 and ML7425

- Accurate valve positioning.
- Quick and easy installation.
- No separate linkage required.
- On power failure:  
ML6425A and ML7425A drive valve stem down.  
ML6425B and ML7425B draw valve stem up.
- Conduit connector is standard.
- No adjustments required.
- True spring return on power failure.
- Low power consumption.
- High close-off ratings.
- Force-limiting end switches.
- Direct/reverse action.
- Synchronous motor.
- Corrosion resistant design.
- Maintenance free.

### ML7425

- Position Feedback signal.
- Fail-safe position selection for control signal loss.

## APPLICATION

The ML6425 Spring Return Electric Linear Valve Actuators are floating control actuators used with controllers that provide a switched or floating single-pole double-throw (spdt) output. These actuators operate standard Honeywell valves in heating, ventilating, and air conditioning (HVAC) applications.

The ML7425 Spring Return Electric Linear Valve Actuators are modulating control actuators used with controllers that provide an analog output of 0 to 10 Vdc or 2 to 10 Vdc. These actuators operate standard Honeywell valves in heating, ventilating, and air conditioning (HVAC) applications. An internal selector can be used to reverse the direction of action.

### Contents

Application .....	1
Specifications .....	2
Ordering Information .....	2
Installation .....	3
Wiring .....	4
Operation .....	7
Checkout .....	8



## SPECIFICATIONS

**Models:**

Model	Spring Return Action	Description
ML6425A	Drive valve stem down on power failure	Electric Linear Valve Actuator
ML7425A		
ML6425B	Draw valve stem up on power failure	
ML7425B		

**Dimensions:** Refer to Fig. 1.

**Weight:** 5.1 lb (2.3 kg).

**Electrical Ratings:**

Power Input: 24 Vac ±15%, 60 Hz.

Power Consumption:

ML6425: 11 VA maximum at 24 Vac.

ML7425: 12 VA maximum at 24 Vac.

Signal Source Output Resistance: 1 kOhm maximum.

Signal Load: 1 mA maximum.

**Signal Inputs (Supply Voltage Between Terminals):**

ML6425:

B and 24 Vac: Drive valve stem down.

W and 24 Vac: Draw valve stem up.

ML7425: 0 to 10 Vdc or 2 to 10 Vdc.

**Stem Force:** 135 lbf (600 N).

**Actuator Stroke:** 3/4 in. (19 mm).

**Actuator Run Time at 60 Hz:** 90 seconds.

**Spring Return Time:** 12 seconds.

**Temperature Ranges:**

Ambient: 14° to 122° F (-10° to +50° C).

Storage: -40° to +158° F (-40° to +70° C).

Maximum Valve Medium: 300° F (149° C).

**Humidity:** 5 to 95 percent relative humidity, noncondensing.

**Close-off Pressure Ratings:** Refer to Table 1.

**Protection Standard:** IP54.

**Approvals:**

Underwriter's Laboratories, Inc. UL94-5V Flame Retardant.

Meets CE requirements.

**Cable entry:** Conduit connector and one knockout on case.

**Actuator Material:**

Cover: ABS-FR plastic.

Base: PBTP-FR plastic.

Yoke: Diecast aluminum.

**Accessories:**

- 43196000-001 High Temperature Kit (for actuators with 3/4 in. stroke). Increases the maximum temperature to 428°F (220°C).

**ML6425 Only**

- 43191679-111 Single Auxiliary Potentiometer (10K ohm).
- 43191679-112 Single Auxiliary Potentiometer (220 ohm).
- 43191680-105 Dual Auxiliary Switch (24 Vac use only).

## ORDERING INFORMATION

When purchasing replacement and modernization products from your TRADELINE® wholesaler or distributor, refer to the TRADELINE® Catalog or price sheets for complete ordering number. If you have additional questions, need further information, or would like to comment on our products or services, please write or phone:

1. Your local Honeywell Environmental and Combustion Controls Sales Office (check white pages of your phone directory).
2. Honeywell Customer Care  
1885 Douglas Drive North  
Minneapolis, Minnesota 55422-4386
3. <http://customer.honeywell.com> or <http://customer.honeywell.ca>

International Sales and Service Offices in all principal cities of the world. Manufacturing in Belgium, Canada, China, Czech Republic, Germany, Hungary, Italy, Mexico, Netherlands, United Kingdom, and United States.

**Table 1. Close-off Ratings for ML6425, ML7425 Electric Linear Valve Actuators and Honeywell Valves (psi).**

Type	Valve	1/2 in.	3/4 in.	1 in.	1-1/4 in.	1-1/2 in.	2 in.	2-1/2 in.	3 in.
Flange	V5011A	—	—	—	—	—	—	28	16
	V3350/ 3351/ 3450/ 3451	—	—	—	—	—	—	21	14
	V5013B, C; V3360/ 3361/ 3460/ 3461	—	—	—	—	—	—	21 <sup>a</sup>	14 <sup>a</sup>
NPT	V5011F, G	150 <sup>b</sup>	150 <sup>b</sup>	150 <sup>b</sup>	134 <sup>b</sup>	77	49	28	16
	V5011H, J	150	150	150	145	—	—	—	—
	V5011N1xxx, V5011N3xxx, V5013N	230	230	163	104	67	37	—	—
	V5011N2xxx	100	100	100	100	67	37	—	—
	V5013F	150	150	150	126	77	49	—	—

<sup>a</sup>Represents maximum pressure difference between the outlet and either of the two inlets.

<sup>b</sup>Do not exceed 100 psi with V5011G valves used in steam applications.

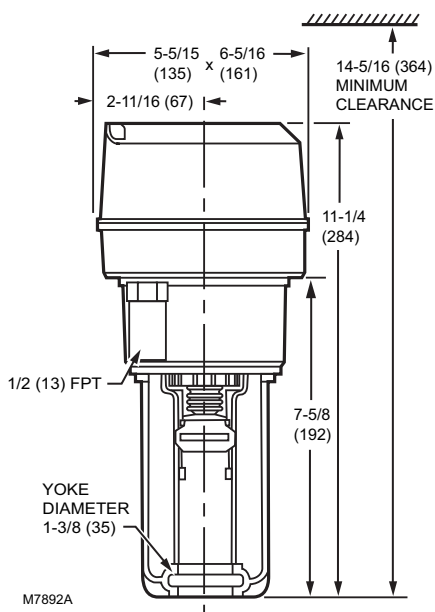

**Fig. 1. Approximate Dimensions of ML6425, ML7425 Electric Linear Valve Actuator in in. (mm).**

## INSTALLATION

### When Installing this Product...

1. Read instructions carefully. Failure to follow them could damage the product or cause a hazardous condition.
2. Check ratings and description given in the specifications to make sure the product is suitable for your application.
3. Installer must be a trained, experienced service technician.
4. After installation is complete, check out product operation as provided in these instructions.



### CAUTION

**Electrical Shock or Equipment Damage Hazard.**  
**Can shock individuals or short equipment circuitry.**  
 Disconnect power supply before installation.

### Location

Install the actuator in a location that allows enough clearance for mounting accessories and for servicing.



### CAUTION

**Equipment Damage Hazard.**  
**Can damage actuator due to condensation or a valve gland leak.**  
 Install the actuator in a position above horizontal.

### Mounting

1. Place the actuator on the valve with the U-bolt around the valve collar (Refer to Fig. 2).
2. Place the U-bolt against the valve collar and secure the actuator to the valve by turning each U-bolt nut clockwise. To assure even pressure on the collar, first tighten the nuts finger-tight and then alternate turning each U-bolt nut until both are snug.
3. Push aside the stem button retaining clip and hold (Refer to Fig. 3).
4. Lift valve stem until the head of the valve stem button is inside the large slot of the stem button retaining clip on the actuator.
5. Release the stem button retaining clip to secure the stem button. Check to make certain the stem button is secured by the retaining clip.
6. Remove the cover from the actuator using a Phillips or crosspoint screwdriver (Refer to Fig. 4).



### CAUTION

**Personal Injury Hazard.**  
**Manual spring handle under tension can turn quickly when lifted, pinching fingers between handle and plastic casing.**  
 Use a screwdriver to lift and release manual spring handle (Refer to Fig. 5).

7. Remove the manual spring handle retaining clip, and lift and release the handle (Refer to Fig. 5). The easiest way to perform this operation safely is to:
  - a. Remove the retaining clip.
  - b. Wedge a small, flat-bladed screwdriver under the manual spring handle and pry up the handle (Refer to Fig. 5).

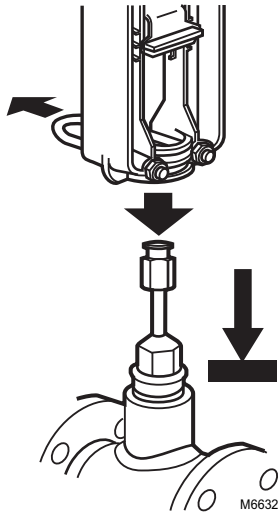

Fig. 2. Attaching Actuator to Valve Collar.

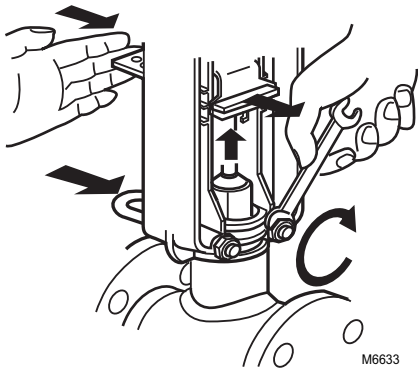

Fig. 3. Securing Actuator to Valve.

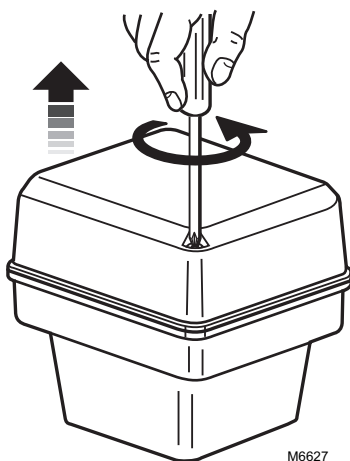

Fig. 4. Removing Actuator Cover.

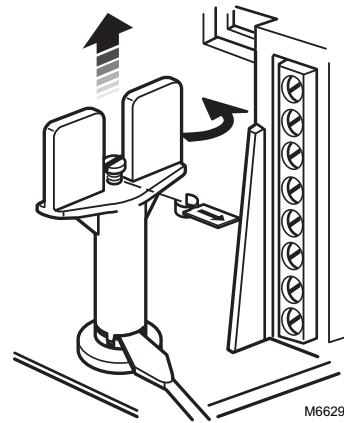

Fig. 5. Removing Spring Retaining Clip and Releasing Manual Spring Handle.

## WIRING



### CAUTION

**Electrical Shock or Equipment Damage Hazard.**  
Can shock individuals or short equipment circuitry.  
Disconnect power supply before installation.

All wiring must comply with local electrical codes, ordinances and regulations. Voltage and frequency of the transformer used with the actuator must correspond with the power supply and actuator characteristics. Refer to Figures 6 through 13 for connection information and typical wiring hookups.

1. Feed power and control wires through the conduit connector located on the bottom of the actuator case (See Fig. 6).



### CAUTION

**Equipment Damage Hazard.**  
Conduit connection or removal can break an unsupported connector.  
When removing or attaching conduit, use a wrench to support the motor connector.

2. Using the wiring diagram in Fig. 7, connect power and control wires. Make sure that all wiring is correct.
3. When wiring is complete, replace the cover on the actuator (Refer to Fig. 14).
4. Apply power and control signals to the actuator.

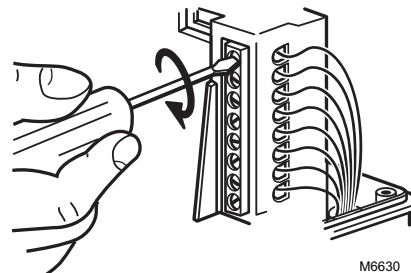

Fig. 6. Connecting Power and Control Wiring.

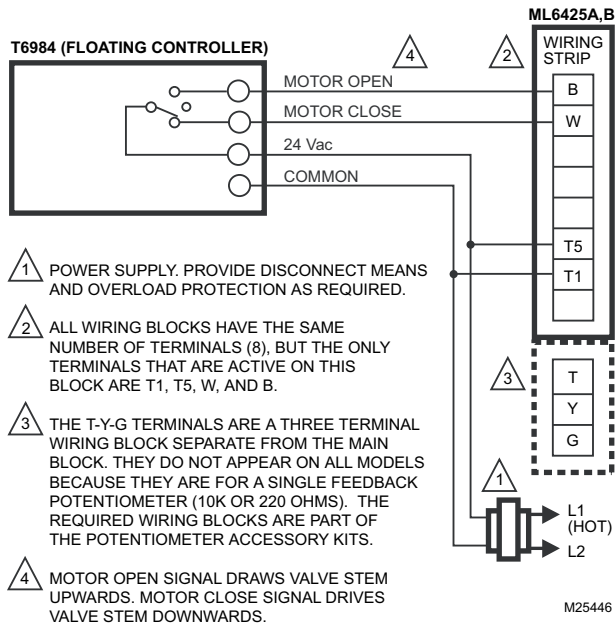

Fig. 7. ML6425 Wiring.

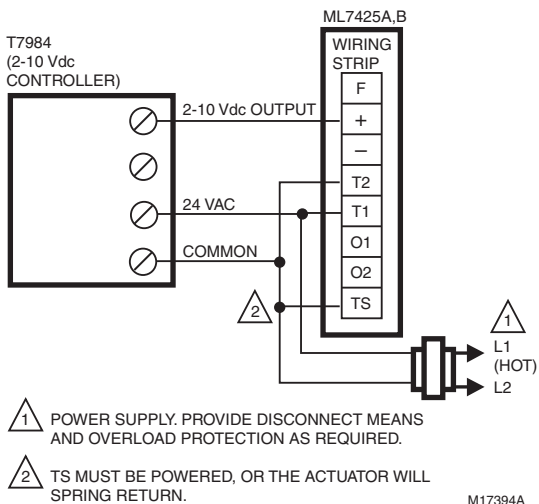

Fig. 8. ML7425 Wiring.

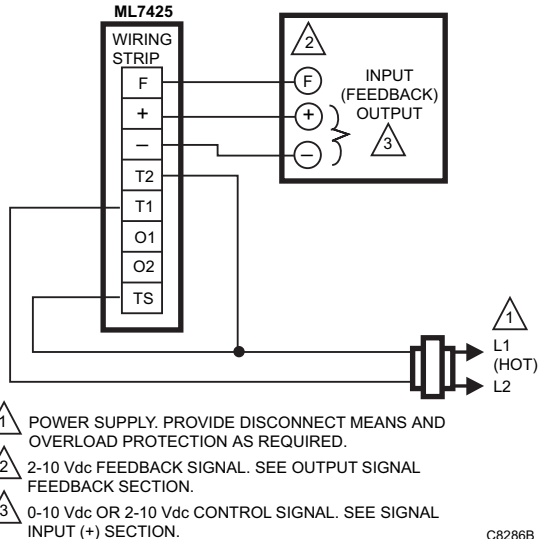

Fig. 9. ML7425 Wiring using Controller Feedback Output and a Common Transformer.

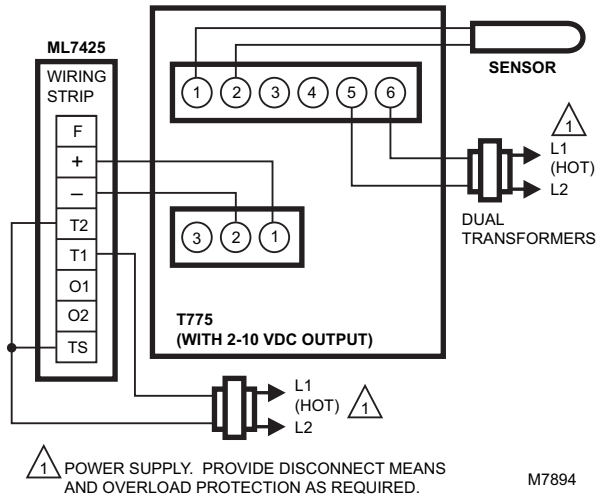

Fig. 10. ML7425 Wiring using 2 to 10 Vdc Control Signal and Separate Transformers.

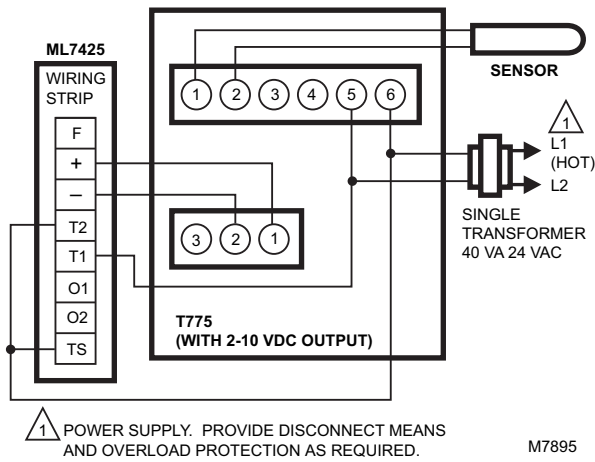

Fig. 11. ML7425 Wiring using 2 to 10 Vdc Control Signal and a Common Transformer.

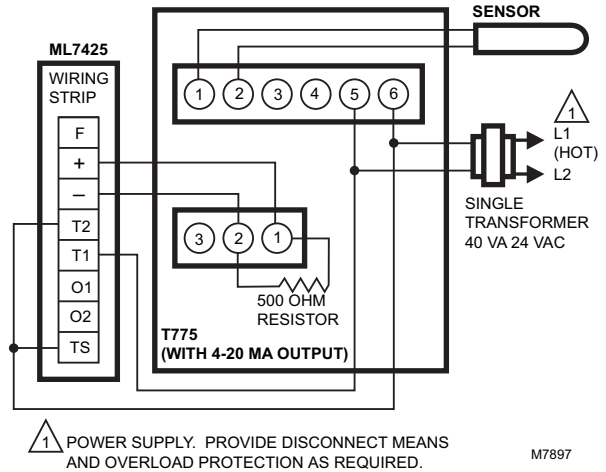

Fig. 13. ML7425 Wiring using 4 to 20 mA Control Signal and a Common Transformer.

NOTE: 500 ohm resistor not shipped with product.

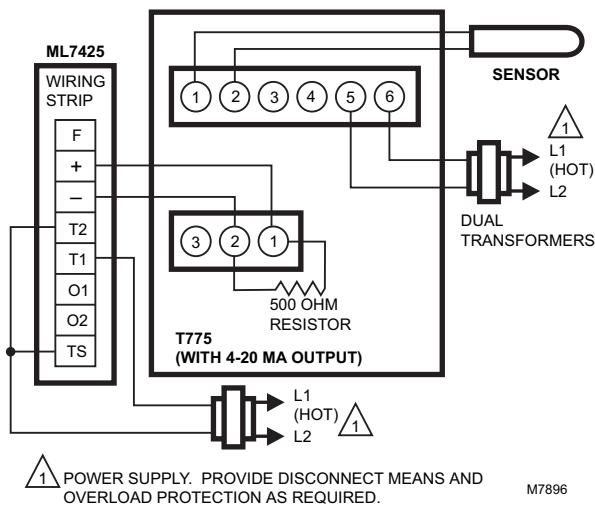

Fig. 12. ML7425 Wiring using 4 to 20 mA Control Signal and Separate Transformers.

NOTE: 500 ohm resistor not shipped with product.

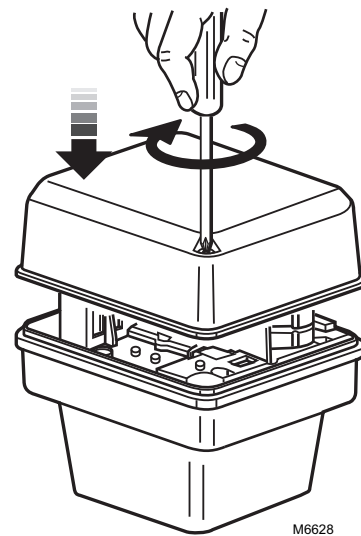

Fig. 14. Replacing Actuator Cover.

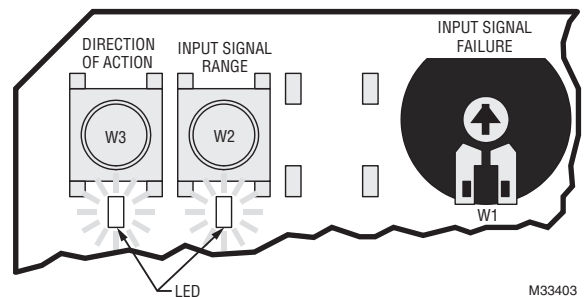

Fig. 15. Pushbuttons and potentiometer (default positions).

## Auxiliary Potentiometers

The 43191679 Auxiliary Potentiometers can be used as feedback potentiometers and to provide remote indication of the valve position. Refer to the Installation Instructions packed with the potentiometers.

## Auxiliary Switches



### CAUTION

**Equipment Damage Hazard.**  
Improper voltage will damage the auxiliary switch beyond repair.

Use the 43191680 Dual Auxiliary Switch only with 24 Vac applications.

The 43191680 Dual Auxiliary Switch can be used on both the ML6425 and ML7425 Electric Linear Valve Actuators. Switching points are adjustable over the full length of actuator stroke; for example, the switch can be used to switch pumps or provide remote indication of any stroke position. Refer to the Installation Instructions packed with the auxiliary switch.

## OPERATION

In the actuator, the drive of a synchronous motor is converted into the linear motion of the actuator stem by using a spur gear transmission. A button retainer clip connects the actuator stem to the valve stem.

An integrated spring package limits the stem force to a factory adjusted value in either direction. Installed microswitches turn off the actuator when the specified stem force is reached.

The ML6425, ML7425 Spring Return Valve Actuators provide a safety valve position in the event of power failure. On power failure, the ML6425A and ML7425A extend the actuator stem; the ML6425B and ML7425B retract the actuator stem.

The actuators are shipped from the factory with a spring handle retaining clip installed, so the actuator can be connected to the valve without applying power. Remove this clip after the actuator is installed. (Refer to the Installation section.)

## ML7425

### Signal Input (+)

The range of the analog input signal (+) can be changed by pressing the right-hand pushbutton (W2) located on the printed circuit board (see Fig. 15). If the corresponding LED is lit, this indicates that the actuator is set for 0 to 10 Vdc operation (factory setting); if it is dark, the actuator is set for 2 to 10 Vdc operation.

### Signal Input Failure

Using the potentiometer (W1) located on the printed circuit board (see Fig. 15), the actuator can be adjusted such that in case the signal input fails (e.g., due to a broken wire) or exceeds 12.5 V, the actuator will run to any pre-configured position between 0% and 100%. The factory setting is with the actuator stem in the central position (50%).

**NOTE:** The two pushbuttons (W3 and W2) and the potentiometer (W1) are accessible after the cover has been removed and are located at the rear side of the protection sheet of the printed circuit board.

## Output Signal Feedback (F)

An analog output signal (2 to 10 Vdc) that represents the actual actuator stem position is available at terminal F. It can be used for remote indication of the stem position. When the valve stem is fully downward, the output signal is 10 Vdc.

When the valve stem is up, the output signal is 0 or 2 Vdc. The output of the signal does not change when the action of the actuator is reversed using W3. See Direction of Action.

## Actuator Override

To override the control signal (for freeze protection or similar applications), connect the 24 Vac common (T2) to either terminal O1 or O2. Connecting to terminal O1 fully extends the actuator stem. Connecting to O2 fully retracts the actuator stem.

The control signal (+) is ignored when the override signal is applied to Terminal O1 or O2. This override can be achieved with a switch or a relay (See Fig. 16).

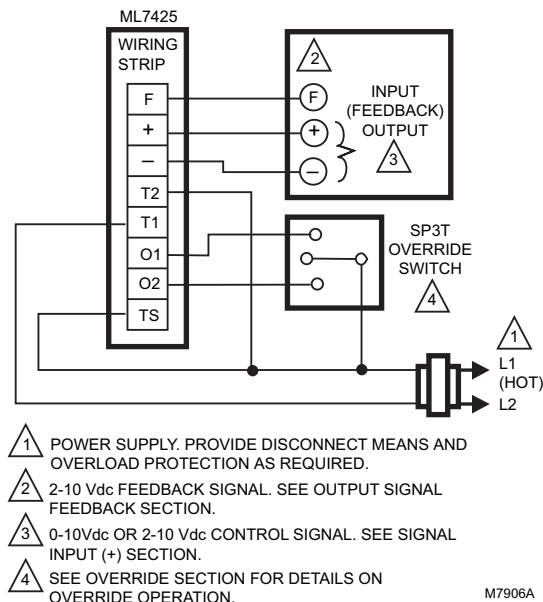

**Fig. 16. Connections for Overriding Control Signal to Drive ML7425 to a Specific Position.**

## Direction of Action (ML7425 only)

The direction of action can be reversed by pressing the left hand pushbutton (W3) located on the printed circuit board (see Fig. 15). If the corresponding LED is lit, this indicates that the actuator stem will be up at a control signal of 0(2) Vdc (factory setting); if it is dark, the actuator stem will be down at a control signal of 0(2) Vdc.

## CHECKOUT

The actuator can be checked out either directly or by using a controller.

### Direct Checkout

1. Mount the actuator for the required application; see Installation section.
2. Check the valve position and make sure that 24 Vac is correctly applied to the actuator.
3. Apply the power to the appropriate leadwires to move the valve.
4. If the actuator does not move, make sure the actuator is properly installed/wired.
5. If the actuator installation and wiring are both correct and the actuator does not run, replace the actuator.

### Controller Checkout

1. Adjust the setpoint of the controller to call for opening the valve. Observe the actuator.
2. If the valve is closed, it should begin to open.
3. If the valve remains closed, move the setpoint further toward the open setting.
4. If the valve does not move, check for 24 Vac in the actuator power input.
5. If 24 Vac is present and the actuator does not operate, check the voltage across the controller leadwires to determine if the device is miswired.
6. If the wiring is correct, 24 Vac is present on the power input terminals, and the actuator does not run, replace the actuator.

By using this Honeywell literature, you agree that Honeywell will have no liability for any damages arising out of your use or modification to, the literature. You will defend and indemnify Honeywell, its affiliates and subsidiaries, from and against any liability, cost, or damages, including attorneys' fees, arising out of, or resulting from, any modification to the literature by you.

### Automation and Control Solutions

Honeywell International Inc.  
1985 Douglas Drive North  
Golden Valley, MN 55422  
customer.honeywell.com

# Honeywell